



DOOR SYSTEM EN81-20/50 EN81-58:2018



CAR DOOR
J2511-T2A



LANDING DOOR
T2203-T2A



For more information please visit www.shbst.com or follow BST Wechat ID:shanghai-bst

Sales Hotline:+86-21-58226513,58225970 Fax:+86-21-58221353 E-mail:export@shbst.com



To A Better Life

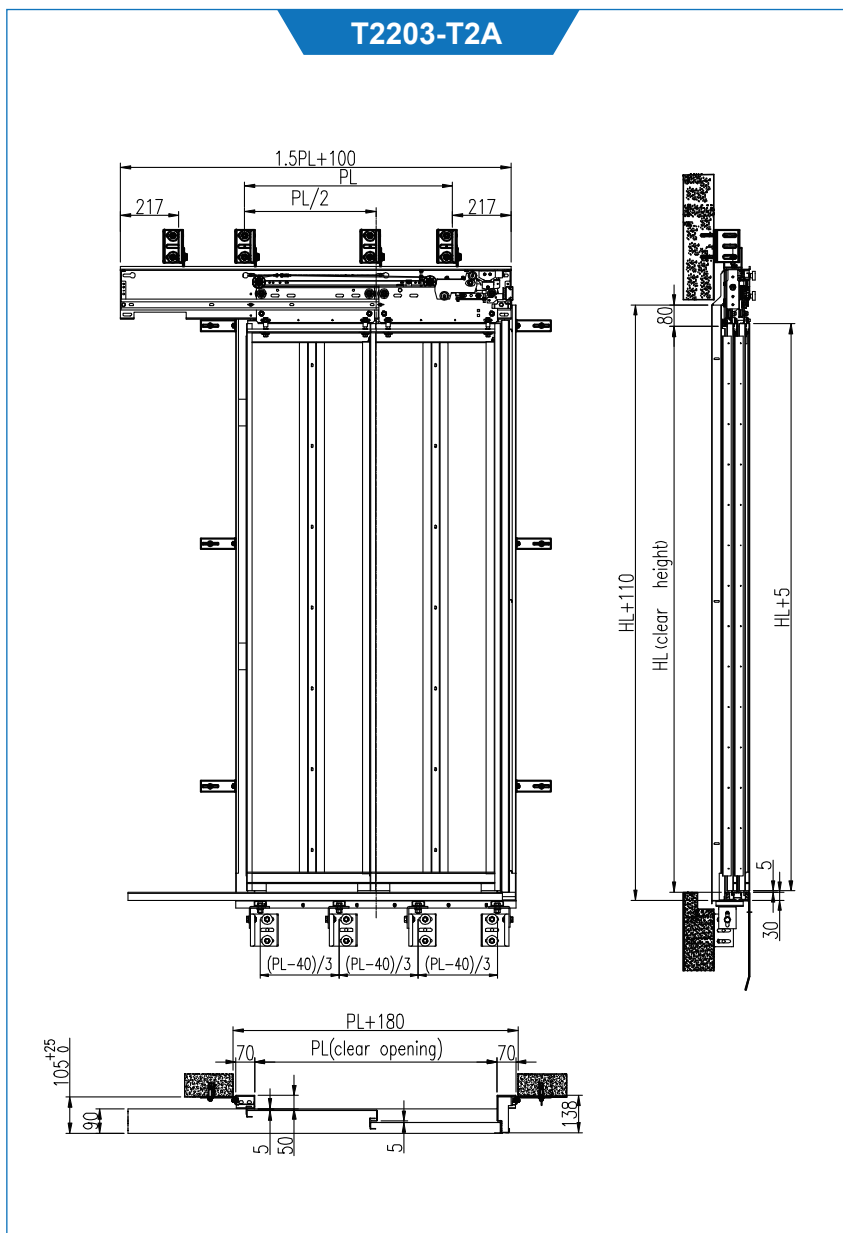

Product Specification:

Door Panel Option	Clear Opening (PL)	Clear Height (HL)	Frame	Sill Option
<ul style="list-style-type: none"> Powder coated Stainless clad 	700~1300 (mm)	2000~2500 (mm)	50*70 (mm)	<ul style="list-style-type: none"> Aluminium sill Stainless steel sill

Product Advantage:

- Optimized structural design of the EI120 door panel;
- Material of heat insulated layer thickness less than 20mm;
- Exhaust gas pollution less than $0.6m^3 / min$, superior to standard requirements $3m^3 / min$;
- High mechanical performance and strength;
- Stable and reliable in operation.

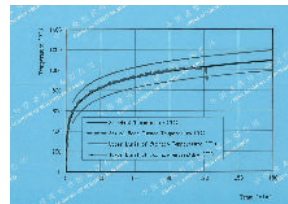

Figure1:Actual mean furnace & standard temperature/time curve

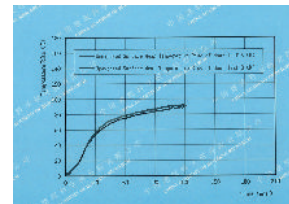

Figure2:Unexposed surface mean temperature of door leaf / time curve

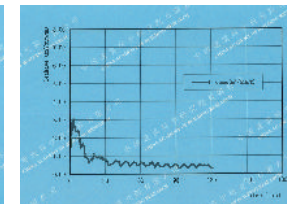

Figure3:Corrected leakage rate per meter width of door opening / time curve

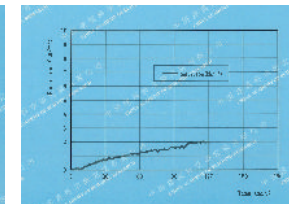

Figure4:Radiation / time curve

Product Certificate:



Landing Doors
EN81-58:2018
2014/33/EU



Landing Door Locking Device
EN81-50:2014
2014/33/EU

